



MESSAGE FROM THE PREZ!

OVAC Members,

Well, I have learned one thing this Spring, don't buy your hanging baskets just before a heat wave. Now I have "very nice" dead hanging baskets. You know, I've never been a knowledgeable outdoor garden or flower person. Indoors – okay!!!

We had a nice turnout for our May meeting. Our Yuma folks are back so they can miss the heat – we fooled them!!!! The individual reports were given with the membership showing 92 processed renewals. Still 20 down from last year. So, come on folks, get those renewals in. We hoped we would top last year's number, but still have a ways to go.

Dana was unable to attend the meeting, but we do know the Swap Meet rentals are still rolling in. Should have a full house with 112 tables reserved for the 21st of October.

There are many car tours and shows being scheduled, so please check Jim Barnes website at cruisinkitsap.com for all the info. And, a big thank you to Jim, for keeping us all informed.

Hope to see you at the get together on the 1st Saturday of the month at 10:00 at the Keyport Mercantile and the 2nd and 4th Thursday of the month at 9:00 at Putters. Also, the ladies lunch on the 3rd Tuesday at 11:30 at Envy in Poulsbo.

If you have the chance to sit it out or dance, I hope you dance.....

Your Madam Prez,
Pat

JUNE 2023

Next Meeting

18 JUNE

Location:

Family Pancake House

3900 Kitsap Way

Bremerton Wa 98312

3pm



In This Issue.....

- Message from PREZ.....1
- Auxiliary Events.....3
- Tours and Events.....4
- 1960 DiDia Car.....5
- 1963 Chrysler Turbine...7
- Meeting Minutes.....10
- Mail Truck.....11

OVAC Business

OVAC OWNER's Manual

The Olympic Vintage Auto Club (OVAC) is a non-profit organization, incorporated in Kitsap County, Washington in 1959. The mission of the Club is the preservation and enjoyment of vintage motor vehicles in stock condition.

The address is **OVAC, PO Box 1614, Silverdale, WA 98383**

Vehicles eligible for touring must be thirty (30) or more years old and have no modifications with the following exceptions: (1) modifications or accessories that were available at the time of manufacture; or (2) changes or additions for safety purposes. Ownership of such a vehicle is not a requirement for membership in OVAC.

Monthly meetings are held the third Thursday of each month, except for the months of January, August, and December.

OVAC OFFICERS

President

Pat Ward ~ spectapper@aol.com ~ 360-621-8747

Vice-President

Pete Britton ~ 360-535-4637

Secretary

Bonnie Chrey ~ bchrey@wavecable.com ~ 360-308-0011

Treasurer

Bob Arper ~ b.arper@comcast.net ~ 360-692-1465

Immediate Past President

Bonnie Chrey ~ bchrey@wavecable.com ~ 360-308-0011

OVAC Committees

Swap Meet Chairman

Pete Britton ~ 360-535-4637

Financial Manager

Bob Arper ~ b.arper@comcast.net ~ 360-692-1465

Vendor Coordinator

Dana Lerma ~ wak9dana@gmail.com ~ 360-710-9890

Historian

Pete Britton ~ 360-535-4637

OVAC Webmaster

Bob Arper ~ b.arper@comcast.net ~ 360-692-1465

The Duster

Britt Feldman ~ brittfeldman@comcast.net ~ 360-620-5001
Editor

****NOTICE****

Ladies Lunch

June 20

(3rd Tuesday of the month)

11:30 ENVY RESTAURANT
Poulsbo Junction

RSVP: Pat Jacobsen or Bonnie Chrey

NOTE: RSVP'S ARE REQUIRED



SWAP MEET SIGNS

Are there any Swap Meet Signs being stored in members garages? Please contact Sig Chrey, either by phone, 360-710-3146, or email bchrey@wavecable.com. We would like to modify the signs to only indicate a Saturday sale and be able to post around the area prior to the

Swap Meet.

Thanks,
Sig Chrey

AUXILIARY EVENTS & NEWS

Coffee—Every Wednesday morning-Envy, Poulsbo, 8:00am

Breakfast—Second and Fourth Thursday of each month
Putters Restaurant, Rolling Hills Golf Course, 9:00am

Port Gamble Cruise-Every Thursday Evening: April through
September Port Gamble, 5:00-7:00pm

Ladies Lunch—3rd Tuesday of the month

McClouds-3rd Saturday of each month

Bremerton National Airport-Car Cruise
from 3:00pm-7:00pm through September

Bainbridge Island Classic Car Cruise-In- Last Tuesday of
each month 5 pm to 8 pm

Find more updates at <https://www.cruisinkitsap.com>



Old Cars And Coffee



- Who** Ovac Members and Prospective Members and old car lovers.
- Where** Established in 1903, the Keyport Mercantile is just about old enough to host this event.
- What** A gathering of old car folks over a cup of Coffee. With the possibility of a local field trip after.
- When** The first Saturday of the month. Bring a friend or a prospective member.

**† Silverdale Lutheran Church
"Cruisin with Christ"**

Car, Truck, Motorcycle and Bike Show
June 10th, 10:00 - 4:00 p.m.

FREE! BBQ, ENTERTAINMENT and ACTIVITIES FOR THE WHOLE FAMILY

More information and online vehicle registration
Scan the QR code or visit:
<https://bit.ly/SLCCruise>

Questions? Contact Debbie Marsch- imdabee@gmail.com
or Sue Shultz-susan.shultz@yahoo.com



The Welcome Mat is out!

Saturday June 10 th, 11 am to 3 PM

Keyport's Garden tour

Art, Glass Studio, Garden Tour and Bake Sale
All Classic and Special Interest cars are invited

Tour the Gardens and enjoy the small town of Keyport

Have an ice cream at the Mercantile
Lunch or libations at the Casa
Enjoy the view of Liberty Bay
Parking and maps available at the Church

A \$10. Donation is suggested for the Garden Tour.
Proceeds to benefit the Keyport Improvement Club.



WE CARE PICNIC AND CAR TOUR 25 AUGUST

**Preliminary Copy
Subject to change!**

Who - Ovac Members, Prospective Members and Kitsap Street Rods.

Where - We will be gathering for a Picnic at the American Legion Park in Poulsbo. Located on Front Street.

What - A picnic followed by a drive through tour of three facilities.

When - Friday 25 August Meeting in the park at 12 pm.

The program

We have been asked to give a Drive By tour of the new Memory Car facility in Silverdale. Ron suggested that we include the folks at Martha and Mary Rehab and Northwoods Lodge since they have been very good to us over the years. I agree, so I have elected to make an afternoon of it.

We will begin with a Picnic at the American Legion Park in Poulsbo (right across the street from Martha and Mary Rehab). Bring your chairs, grub and maybe even your camera. There we can feast, kick tires, swap stories and even walk the boardwalk.

From there we will make two passes through the main entrance at Martha and Mary. From there we will tour down Viking Way to Northwoods, stopping on Silverdale Hill to regroup and gather all of our chickens.

Next stop will be two loops through the complex at Northwoods before touring over to Fieldstone Memory Care.

They are expecting us at Fieldstone around 3 pm. Once there we will make two passes.

2023 TOURS AND EVENT CALENDAR

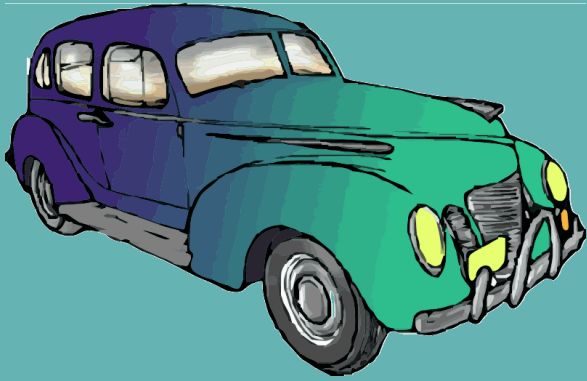

**We have some
events on the
calendar for 2023!!**

JUNE

3-Old Cars and Coffee-10am
10-Silverdale Lutheran
"Crusin w/Christ" 10-4pm
10-11 Keyport Garden Tour
11-3pm
15-Monthly Meeting
25-Retsil 1pm-Arper

JULY

1-Old Cars and Coffee-10am
27-Monthly Meeting
Mission Lake Splash Blast

AUGUST

5-Old Cars and Coffee-10am
25-Fieldstone Memory Care-
3pm
25-We Care Picnic and Car
Tour
No Monthly Meeting

SEPTEMBER

2-Old Cars and Coffee-10am
16-Quilcene Parade and Car
Show -Chrey6
21-Monthly Meeting

OCTOBER

7-Old Cars and Coffee-10am
19-Monthly Meeting
21-OVAC SWAP MEET

NOVEMBER

4-Old Cars and Coffee-10am
16-Monthly Meeting

DECEMBER

2-Old Cars and Coffee-10am
NO Monthly Meeting



Bremerton Auto Swap Meet !



Saturday October 21 st.
2023, 8 am to 4 pm

This will be a one day event.
One building (Presidents Hall).

Located at the Kitsap County Fairgrounds
near Bremerton Washington.

Parking is Free Admission is still \$5.00

For Booth Availability and information you can
call Dana at 360 710-9890
or eMail at ovacsswapmeet2023@gmail.com

This event is hosted by the
Olympic Vintage Auto Club.

Flyers printed
courtesy of



1960 . . . The Bobby Darin "Dream Car"

*When fins were in. What . . . a blind spot?
Therefore they made the rear roof all glass.*



The 1960 DiDia 150 was a luxury, custom-designed iconic, handmade car also known as

the "Dream Car" forever associated with its second owner, singer Bobby Darin. The car was designed by Andrew DiDia, a clothing designer, who Bobby Darin had met whilst on tour in Detroit in 1957. Darin telling DiDia at the time that he would purchase the car if he ever "hit it big." For seven years, from 1953 to 1960 the DiDia 150 was hand-built by four workers, at a cost of \$93,647.29 but sold to Darin in 1961 at a cost of over \$150,000 (1.5 million today). [At the time the car was listed as most expensive 'custom-made' car in the world by the Guinness Book of Records.]



The body was hand-formed by Ron Clark and constructed by Bob Kaiser from Clark Kaiser Customs.

Built in Detroit, Michigan, clothing designer Andrew 'Andy' DiDia designed this "unrestrained and unconventional" automobile. Only one example was ever built. The normal V8 engine is located at the front with an engine displacement of 365/427. It has a rear-wheel drive. The body and chassis is hand-formed from 064 aluminum with a 125-inch wheelbase alloy tube frame.



The design included the first backseat-mounted radio speakers and hidden windshield wipers, that started themselves when it rained. Other features include retractable headlamps, rear indicators that swivel as the car turns, 'floating' bumpers and a trunk that was hinged from the driver's side. Each of the four bucket seats have their own thermostatically controlled air condition, individual cigarette lighters and ashtrays, as well as a radio speaker. The original engine, a Cadillac V8, was later replaced by a 427 high-performance by Ford when it was taken on the show circuit.

Cont'd on page 6

1960 . . . The Bobby Darin "Dream Car" *cont'd*



Darin drove his wife, Sandra Dee, in the car to the 34th Academy Awards in 1961. When Bobby drove the car to the Academy Awards, Andrew DiDia and Steve Blauner followed behind him in a limousine. The car had two fans and a switch that you had to turn on. Bobby didn't realize, so it heated up. All the magazines said the car caught fire but it didn't.

Bobby Darin, at right with pipe in his mouth, age twenty-five, buys his dream car. The car, valued at \$150,000, represented more than six years of planning by Darin and Andrew Di Dia, who built the vehicle. Crushed diamond dust was used in the paint applied in 30 coats to the car. March 1961.

UPI



Di Dia toured the car around the country, when Darin wasn't using it for public appearances. After publicity and film use, Darin donated his "Dream Car" to the St. Louis Museum of Transportation in 1970 where it remains.



A Brief History of the 1963 Chrysler Turbine Car

By Robert Tate, Automotive Historian and Researcher
 Images courtesy of Chrysler Corporation Archives/Motor
 Trend magazine
 Published 5.20.2020

At the end of World War II, Chrysler Corporation's research and development team had started working on a gas turbine engineering project. In the fall of 1945, Chrysler was awarded a contract by the Bureau of Aeronautics of the U.S. Navy to create a turboprop aircraft engine. Unfortunately, the contract would later be terminated in 1949. At that time, Chrysler research scientist team and engineers then returned to their original objective, which was developing an automotive gas turbine engine.



completely new design and offered in one body style only, a four passenger, two-door hardtop. The exterior and interior color was called Turbine Bronze. The model offered power steering, power brakes, power windows and an automatic transmission.

The Chrysler Turbine cars were built at a rate of one per week until the last of the 50 cars were finished in October 1964. The turbine engines were built and tested at Chrysler's Research Laboratories. The objective of the Chrysler Turbine program was to test consumer and market reaction to turbine power and to obtain service data and driver experience with the Turbine cars under a wide variety of conditions.



In the early 1950s, experimental gas turbine power plants were operating on dynamometers and in test vehicles. On March 25, 1954, Chrysler made history by producing the first vehicle powered by a gas turbine engine, a 1954 Plymouth sport coupe. Later, Chrysler would produce more gas turbine vehicles.

This story is about the popular 1963 Chrysler Turbine model that many still remember today. The limited-production 1963 Turbine car was a

Third-generation Chrysler gas turbine
 www.allpar.com

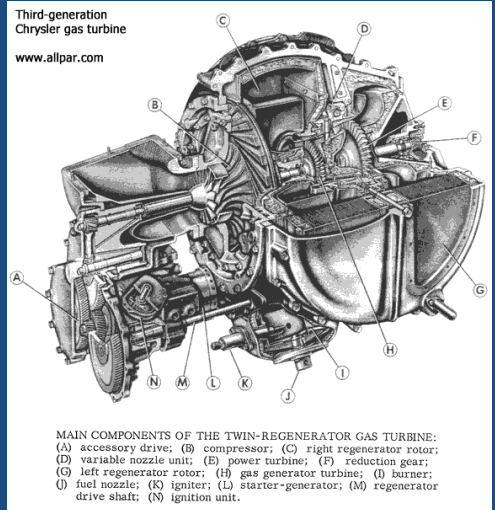

MAIN COMPONENTS OF THE TWIN-REGENERATOR GAS TURBINE:
 (A) accessory drive; (B) compressor; (C) right regenerator rotor;
 (D) variable nozzle unit; (E) power turbine; (F) reduction gear;
 (G) left regenerator rotor; (H) gas generator turbine; (I) burner;
 (J) fuel nozzle; (K) igniter; (L) starter-generator; (M) regenerator drive shaft; (N) ignition unit.

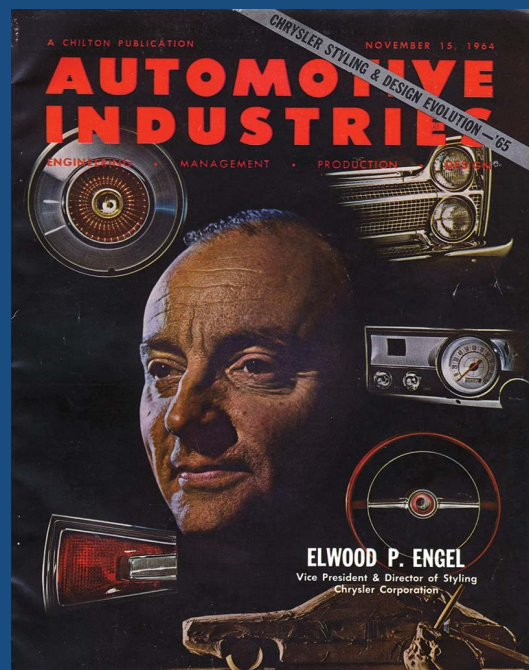

A Brief History of the 1963 Chrysler Turbine Car

The designing and building of the 1963 Chrysler Turbine model was under the direction of Elwood Engel, who replaced Virgil Exner as director of styling in 1961. Engel was very involved with the Chrysler Turbine project. He previously worked at Ford and brought much of their styling influence to his new position. For many years, automotive enthusiasts and historians have said that the 1963 Chrysler Turbine design was influenced by Ford styling.



The Chrysler Turbine offered many great interior features. For example, the circular steering wheel was constructed with copper-toned plastic and had a full metal horn ring with the words "Chrysler Corporation" around the perimeter of the hub. The console controls were within easy reach of the driver's right hand. The front seats were equipped with copper-colored safety belts with concealed floor attachments. The interior was designed to accommodate four passengers comfortably, with individual bucket seats.



Regarding the exterior, the Turbine model also featured a low, thin roof silhouette which was supported by a narrow front pillar and wide rear pillar. The word "Turbine" in bright-metal script appeared on both rear quarters and a gold Pentastar was carried on the right front fender behind the wheel opening. Another distinctive feature that made the Chrysler Turbine stand was the rear end design, which I always thought was great looking. Some automotive historians called it an aerodynamic styling look. The rear deck was flat and wide with those great-looking horizontal tears light design, which many consumers greatly appreciated.



Chrysler Corporation operated a Turbine car consumer research program from October 29, 1963 to October 28, 1965, however, the last driver did not complete her three-month driving report until January 28, 1966. The fundamental qualifying requirements were that a consumer had to own a vehicle or be a member of a household that owned an automobile and could show a valid driver's license. The candidates were selected by the accounting firm of Touche, Ross, Bailey and Smart.

A Brief History of the 1963 Chrysler Turbine Car



The world's first consumer delivery of a Turbine car took place on October 29, 1963 in Chicago. Lynn A. Townsend, president of Chrysler Corporation, presented the keys of the Turbine car to Mr. and Mrs. Richard E. Viaha of Broadview, a suburb of Chicago. The drivers had to give feedback on their experience driving the 1963 Chrysler Turbine models. Chrysler also displayed the Turbine model across the United States in shopping center exhibits and at the New York World's Fair. In total, the model was shown in 23 cities and in 21 countries.

The Turbine car also drew crowds at several college campuses around the country as well.

Unfortunately, Chrysler chose not to manufacture or widely release the car and continued researching the turbine engine, with only a few of these cars surviving today. One is in the collection of our partners at the Detroit Historical Society and was on display at the Detroit Historical Museum a couple years ago.

I once interviewed the late John Henle, the owner and president of Jo Han models in Detroit, who said that the "Chrysler Turbine was the plastic model car that outsold any other model that I had manufactured during the history of Jo Han Models."



In conclusion, the 1963 Chrysler Turbine had an interesting history.

[1963 Turbo in Jay Leno's Garage](#)



OVAC MEETING MINUTES-MAY 18, 2023

Meeting held at Family Pancake House, Kitsap Way, Bremerton, at 3:00PM.

Board members present; Pat Ward – President, Pet Britton – Vice President, Bob Arper – Treasurer/Web Master, Bonnie Chrey – Secretary & Immediate past President.

Members in Attendance – 27, and one guest, Ken Hallis

Meeting called to order by President Pat Ward, with welcoming remarks. The Pledge of Allegiance followed.

New members/guests: No new members.

Sunshine Report – It was reported that long time member Mike Shillinglaw has passed away. His wife is Annabell. A card will be sent to the family.

Last Meeting minutes – A motion was made and seconded to approve the minutes as published in the Duster. Motion carried.

Treasurer's report – Bob had handed out the financial report to the members prior to the meeting for review. At this point we have 92 members, down from last year. He has received 2 renewals since last meeting. He has been receiving monies from Swap Meet Vendors via Dana. There are more reservations coming in. Bob also reported costs so far this month are \$81.03 for printed copies of the Duster. At this point, Secretary Bonnie announced that last fall a \$500 donation was made to the club by a relatively new member. She wanted others to be aware of this generosity.

Swap Meet report – Jim has the printed flyers for the Swap Meet, after corrections had to be made. He has already passed them out, and had more to hand out. Pete Britton, chairman, reported he has handed out flyers. Our guest, Ken Hallis, had a presentation for us; he works with the Boy Scouts, and would like to offer their services if we had a Car Corral to of-

fer. He is with Troop 1571 from Poulsbo. We would split the monies they made. This brought up quite a discussion; what other events are being held at that time, where would we park cars, how much extra would it cost for spaces, insurance or liability issues?. It was suggested that this should be discussed at a meeting called by Chairman, Pete Britton, to include "Swap Meet Committee members". Bonnie gave a business card for a coffee vendor (to serve the public) to Ron Muhleman. Sig Chrey asked about our roadside signs. Could they be modified to just say "Saturday Swap Meet"? Sig will coordinate. He will publish a request in the Duster to find out who/where our signs are. Jim Barnes thinks there JUNE be signs in the storage unit.

Old Business – President Pat reminded all that our July meeting will be held a week later to coordinate with our picnic at Bob & Bev's place. This will be July 27.

The Ladies Lunch, which had to be moved for the JUNE gathering, will again be the 3rd Tuesday, at Envy Restaurant in Poulsbo. This will be June 20th.

The first Saturday of June, which will be June 3, is the Old Cars and Coffee gathering at the Merc in Keyport.

Bob Arper mentioned that a family wondered if anyone would like to take an old car to Key Center on June 2 for a birthday celebration. He has sent out an email about this.

New Business – Secretary Bonnie announced that the 1931 Chevy Mail Truck that a crew of OVAC members restored for the Kitsap History Museum was going to be in the Bremerton Armed Forces Parade on JUNE 20th. Our own Ron O'Neill is going to drive it! Encouraged members to watch parade.

Bob Muhleman is coordinating a car show at Bay Pt. Assisted Living community on July 8, 11 to 1. There will be a picnic, and music. Let him know if you want to go; b.muhleman@hotmail.com. Space is limited.

Cont'd on page 11

OVAC Meeting Minutes-*continued*

There was a request from Fieldstone Memory Care Facility in Silverdale for a drive thru Aug 25 at last months meeting. Jim and George are trying to plan a drive thru at some other facilities that same day, ending at Fieldstone.

Ron Muhleman reported he still had some openings for the West Sound Tech car show on JUNE 26. Contact him if you want to go.

Other tours were discussed. It was mentioned to check Jim Barnes website; cruisinkitsap.com for a full listing of upcoming events.

It was mentioned that there is a free tire collection event coming to the stadium at the Fairgrounds on June 10, from 9 to 3.

President Pat again announced there is a need for officer recruitment for the positions of President and Secretary of OVAC. Pat and Bonnie will not be continuing in their positions for the 2024 year.

Motion to adjourn at 4:00PM. Seconded and approved.



Mail Truck



JUNE 2023

11

THE DUSTER

OVAC



**Olympic Vintage Auto Club
P.O. Box 1614
Silverdale, WA 98383**



JUNE 2023

THE DUSTER